

QXP29B4-10D-3

100Gb/s QSFP28 LR4 Transceiver

PRODUCT FEATURES

- Compliant with 100GBASE-LR4
- Support line rates to 103.125 Gbps
- Integrated LAN WDM DML TOSA / PIN ROSA for up to 10 km reach over SMF
- Digital Diagnostics Monitoring Interface
- Duplex LC optical receptacle
- No external reference clock
- Electrically hot-pluggable
- Compliant with QSFP28 MSA with LC connector
- Case operating temperature range:0 to 70 °C
- Power dissipation < 4.5W

APPLICATIONS

- 100G Ethernet

STANDARD

- Compliant to IEEE 802.3ba
- Compliant to SFF-8636

General Description

XGIGA 100G QSFP28 LR4 optical Transceiver integrates receiver and transmitter path on one module. The laser drivers control 4- Distributed Feedback Laser (DFB) with center wavelength of 1296 nm, 1300nm, 1305nm and 1309 nm. The optical signals are multiplexed to a single –mode fiber through an industry standard LC connector. In the receive side, the four lanes of optical data streams are optically de-multiplexed by the integrated optical de-multiplexer. Each data stream is recovered by a PIN photo-detector and trans-impedance amplifier, retimed. This module features a hot-pluggable electrical interface, low power consumption and 2-wire serial interface.

The product is designed with form factor, optical/electrical connection and digital diagnostic interface according to the QSFP28 Multi-Source Agreement (MSA) and compliant to IEEE 802.3ba.

I Absolute Maximum Ratings

Parameter	Symbol	Min.	Typ.	Max.	Unit	Note
Storage Temperature	Ts	-40	-	85	℃	
Relative Humidity	RH	5	-	95	%	
Power Supply Voltage	VCC	-0.3	-	4	V	
Signal Input Voltage		Vcc-0.3	-	Vcc+0.3	V	

II Recommended Operating Conditions

Parameter	Symbol	Min.	Typ.	Max.	Unit	Note	
Case Operating Temperature	Tcase	0	-	70	℃		
Power Supply Voltage	VCC	3.13	3.3	3.47	V		
Power Supply Current	ICC	-		1360	mA		
Data Rate	BR		25.78125		Gbps	Each channel	
Transmission Distance	TD		-	10	km		
Coupled fiber		Single mode fiber					9/125um SMF

III Optical Characteristics

Parameter	Symbol	Min	Typ	Max	Unit	NOTE
Transmitter						

Signaling Speed per Lane			25.78125 ± 100 ppm		Gbps	
Wavelength Assignment	λ 0	1294.53	1295.56	1296.59	nm	
	λ 1	1299.02	1300.05	1301.09	nm	
	λ 2	1303.54	1304.58	1305.63	nm	
	λ 3	1308.09	1309.14	1310.19	nm	
Total Output. Power	P _{OUT}			10.5	dBm	
Transmit OMA per Lane		-1.3		4.5	dBm	
Average Launch Power Per lane		-4.3		4.5	dBm	
SMSR		30			dB	
Optical Extinction Ratio	ER	4			dB	
Average launch Power off per lane	P _{off}			-30	dBm	
RIN	RIN			-130	dB/Hz	
Output Eye Mask definition {X1, X2, X3, Y1, Y2, Y3}	{0.25, 0.4, 0.45, 0.25, 0.28, 0.4}					1
Receiver						
Signaling Speed per Lane			25.78125 ± 100 ppm		Gbps	
Wavelength Assignment		1294.53	1295.56	1296.59	nm	
		1299.02	1300.05	1301.09	nm	
		1303.54	1304.58	1305.63	nm	
		1308.09	1309.14	1310.19	nm	
Receive Power (OMA) per Lane	R _{OMA}			4.5	dBm	
Average Input Power per Channel	R _{XPx}	-10.6		4.5	dBm	2
Receiver Sensitivity (OMA) per Lane	R _{xsens}			-8.6	dBm	
LOS De-Assert	LOSD			-12	dBm	
LOS Assert	LOSA	-30			dBm	
Receiver Reflectance	R _r			-26	dB	

Notes:

1. Hit ratio 5×10^{-5} .
2. Measured with a PRBS $2^{31}-1$ test pattern, @25.78Gb/s, BER < 10^{-12} .

IV. Electrical Characteristics

Parameter	Symbol	Min	Typ	Max	Unit	NOTE
Supply Voltage	Vcc	3.13	3.3	3.47	V	
Supply Current	Icc			1360	mA	
Transmitter						
Input differential impedance	Rin		100		Ω	1
Differential data input swing	Vin,pp	180		1000	mV	
Transmit Disable Voltage	VD	Vcc-1.3		Vcc	V	
Transmit Enable Voltage	VEN	Vee		Vee+ 0.8	V	2
Receiver						
Differential data output swing	Vout,pp	300		850	mV	3
LOS Fault	VLOS fault	Vcc-1.3		VccHOST	V	4
LOS Normal	VLOS norm	Vee		Vee+0.8	V	4

Notes:

1. Connected directly to TX data input pins. AC coupled thereafter.
2. Or open circuit.
3. Into 100 ohms differential termination.
4. Loss Of Signal is LVTTTL. Logic 0 indicates normal operation; logic 1 indicates no signal detected.

V. Pin Assignment

Figure 1---Pin out of Connector Block on Host Board

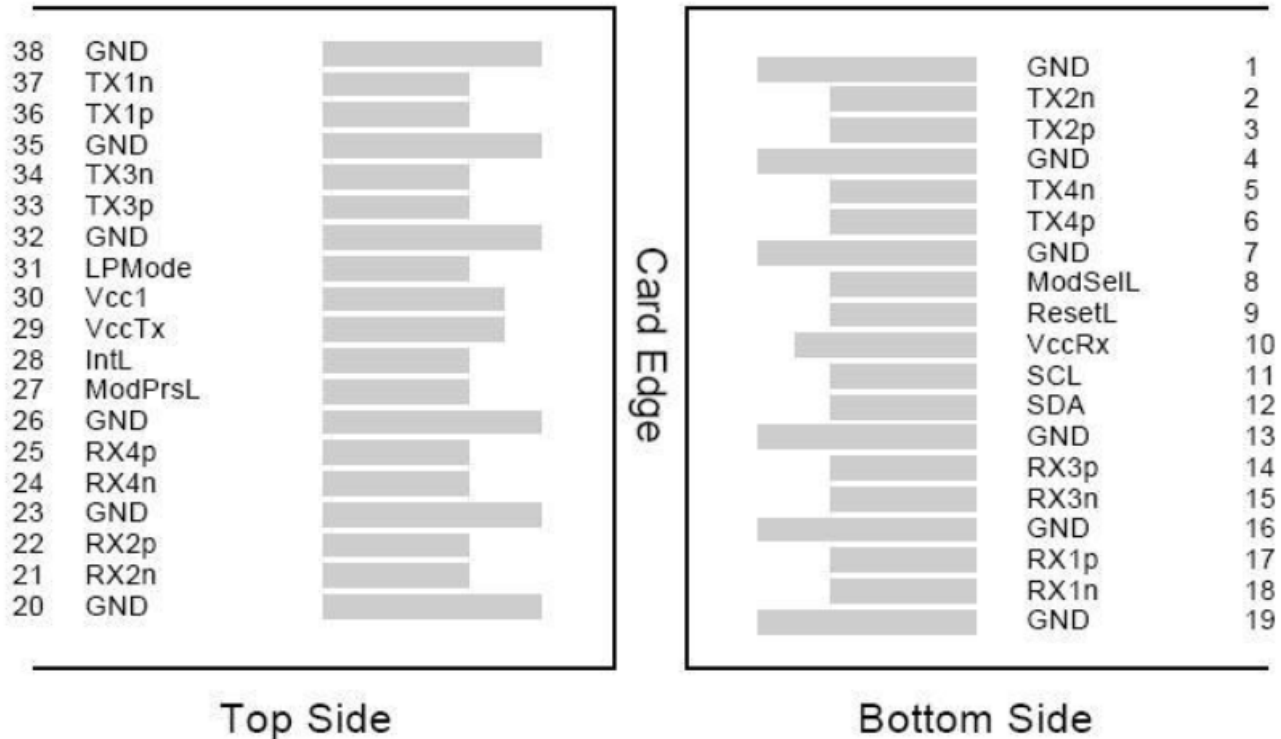

Pin	Symbol	Name/Description	NOTE
1	GND	Transmitter Ground (Common with Receiver Ground)	1
2	Tx2n	Transmitter Inverted Data Input	
3	Tx2p	Transmitter Non-Inverted Data output	
4	GND	Transmitter Ground (Common with Receiver Ground)	1
5	Tx4n	Transmitter Inverted Data Input	
6	Tx4p	Transmitter Non-Inverted Data output	
7	GND	Transmitter Ground (Common with Receiver Ground)	1
8	ModSelL	Module Select	
9	ResetL	Module Reset	
10	VccRx	3.3V Power Supply Receiver	2
11	SCL	2-Wire serial Interface Clock	
12	SDA	2-Wire serial Interface Data	
13	GND	Transmitter Ground (Common with Receiver Ground)	
14	Rx3p	Receiver Non-Inverted Data Output	
15	Rx3n	Receiver Inverted Data Output	
16	GND	Transmitter Ground (Common with Receiver Ground)	1
17	Rx1p	Receiver Non-Inverted Data Output	
18	Rx1n	Receiver Inverted Data Output	
19	GND	Transmitter Ground (Common with Receiver Ground)	1
20	GND	Transmitter Ground (Common with Receiver Ground)	1
21	Rx2n	Receiver Inverted Data Output	

22	Rx2p	Receiver Non-Inverted Data Output	
23	GND	Transmitter Ground (Common with Receiver Ground)	1
24	Rx4n	Receiver Inverted Data Output	1
25	Rx4p	Receiver Non-Inverted Data Output	
26	GND	Transmitter Ground (Common with Receiver Ground)	1
27	ModPrsl	Module Present	
28	IntL	Interrupt	
29	VccTx	3.3V power supply transmitter	2
30	Vcc1	3.3V power supply	2
31	LPMODE	Low Power Mode	
32	GND	Transmitter Ground (Common with Receiver Ground)	1
33	Tx3p	Transmitter Non-Inverted Data Input	
34	Tx3n	Transmitter Inverted Data Output	
35	GND	Transmitter Ground (Common with Receiver Ground)	1
36	Tx1p	Transmitter Non-Inverted Data Input	
37	Tx1n	Transmitter Inverted Data Output	
38	GND	Transmitter Ground (Common with Receiver Ground)	1

Notes:

1. GND is the symbol for signal and supply (power) common for QSFP28 modules. All are common within the QSFP28 module and all module voltages are referenced to this potential unless otherwise noted. Connect these directly to the host board signal common ground plane.
2. VccRx, Vcc1 and VccTx are the receiving and transmission power suppliers and shall be applied concurrently. Recommended host board power supply filtering is shown below. Vcc Rx, Vcc1 and Vcc Tx may be internally connected within the QSFP28 transceiver module in any combination. The connector pins are each rated for a maximum current of 500mA.

VI. Digital Diagnostic Functions

XGIGA QXP29B4-10D-3 support the 2-wire serial communication protocol as defined in the QSFP28 MSA. Which allows real-time access to the following operating parameters:

- Transceiver temperature
- Laser bias current
- Transmitted optical power
- Received optical power
- Transceiver supply voltage

It also provides a sophisticated system of alarm and warning flags, which may be used to alert end-

users when particular operating parameters are outside of a factory-set normal range.

The operating and diagnostics information is monitored and reported by a Digital Diagnostics Transceiver Controller inside the transceiver, which is accessed through the 2-wire serial interface. When the serial protocol is activated, the serial clock signal (SCL pin) is generated by the host. The positive edge clocks data into the QSFP28 transceiver into those segments of its memory map. The negative edge clocks data from the QSFP28 transceiver. The serial data signal (SDA pin) is bi-directional for serial data transfer. The host uses SDA in conjunction with SCL to mark the start and end of serial protocol activation. The memories are organized as a series of 8-bit data words that can be addressed individually or sequentially. The 2-wire serial interface provides sequential or random access to the 8 bit parameters, addressed from 00h to the maximum address of the memory.

This clause defines the Memory Map for QSFP28 transceiver used for serial ID, digital monitoring and certain control functions. The interface is mandatory for all QSFP28 devices. The memory map has been changed in order to accommodate 4 optical channels and limit the required memory space. The structure of the memory is shown in Figure 2 -QSFP28 Memory Map. The memory space is arranged into a lower, single page, address space of 128 bytes and multiple upper address space pages. This structure permits timely access to addresses in the lower page, e.g. Interrupt Flags and Monitors. Less time critical entries, e.g. serial ID information and threshold settings, are available with the Page Select function. The structure also provides address expansion by adding additional upper pages as needed. For example, in Figure 2 upper pages 01 and 02 are optional. Upper page 01 allows implementation of Application Select Table, and upper page 02 provides user read/write space. The lower page and upper pages 00 and 03 are always implemented. The interface address used is A0xh and is mainly used for time critical data like interrupt handling in order to enable a “one-time-read” for all data related to an interrupt situation. After an Interrupt, IntL, has been asserted, the host can read out the flag field to determine the effected channel and type of flag.

For more detailed information including memory map definitions, please see the QSFP28 MSA Specification.

VII. Host - Transceiver Interface Block Diagram

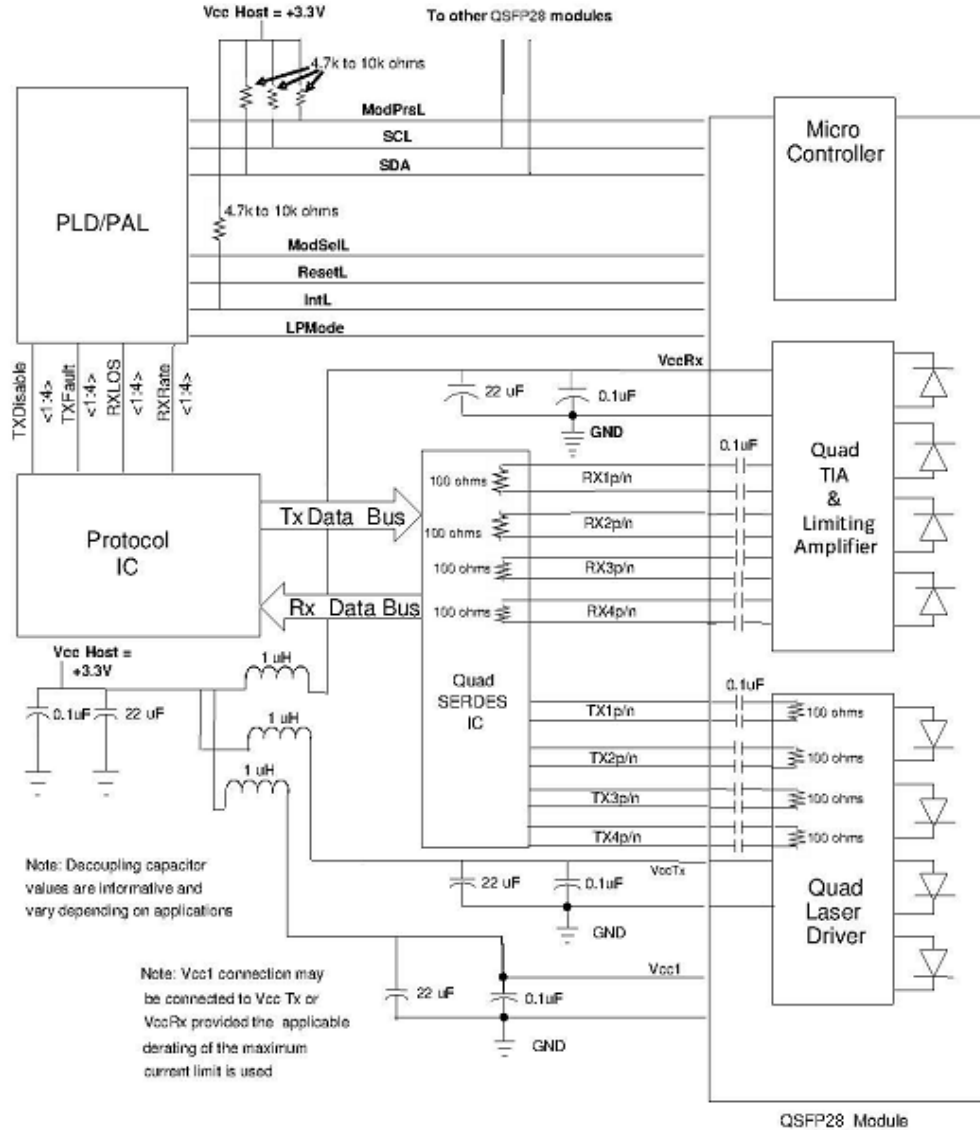

VIII. Outline Dimensions

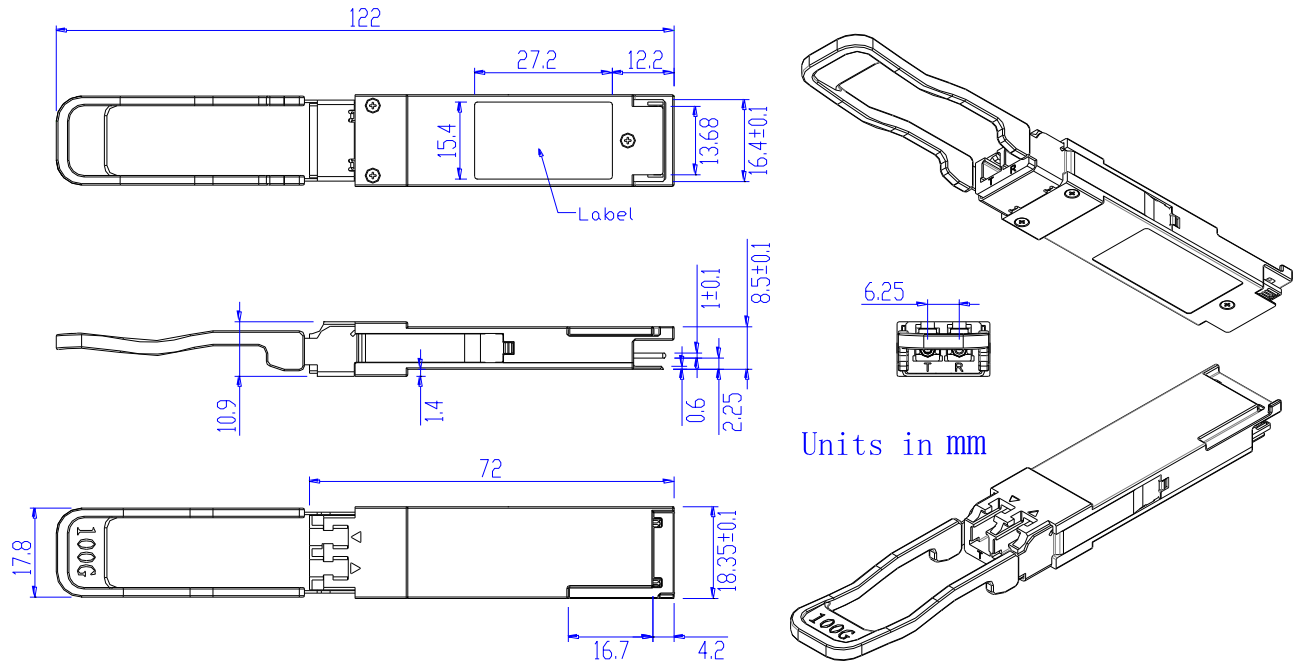

Appendix A. Document Revision

Version No.	Date	Description
1.0	2019-08-07	Preliminary datasheet
2.0	2020-10-13	Update Power dissipation to 4.5W
3.0	2021-03-04	Change PN QXP29B4-10D to QXP29B4-10D-3(Generation2)